

PX™ 10.10-MV

Non-Palletized Freight X-ray System



Security & Detection Systems

Powerful, Modular, Configurable. The most flexible multi-view X-ray for non-palletized freight

Serving the needs of airport baggage and postal facilities, freight forwarders and other air cargo break bulk screeners, the PX 10.10-MV handles a wide variety of packages and freight, including oversized/out-of-gauge cartons and irregularly shaped items.

The PX 10.10-MV offers unparalleled imaging performance and flexibility in a 1 meter tunnel. The system combines an optimal belt height and imaging ratio delivering exceptional imaging performance and minimizing manual handling issues. The PX 10.10-MV has a vertical geometry primary view with an optional secondary view module that is horizontal. The system also comes standard with L-3's latest high-current X-ray source. The combination of vertical geometry and high-powered tank deliver

the ultimate in penetration, image resolution and quality to facilitate the rapid detection of multiple targets including weapons, narcotics, explosives and other contraband.

The system boasts a modular architecture with segments that can be wheeled individually through a standard doorway and quickly reconnected – allowing the system to be deployed in many areas previously only accessible to much smaller units. This modular architecture also makes it easy to add a second view so customers can choose a dual-view configuration or a single-view system that can later be upgraded in the field.

With the new multi-language support* capability, operators can interact with a system that speaks their native language.



Monitor included but not shown
Dual-view Illustration

APPLICATIONS

- Threat detection
- Manifest and declaration verification
- Contraband detection
- Theft prevention



The L-3 Advantage. Reflecting L-3's commitment to innovation and its long experience in X-ray solutions, the PX 10.10-MV offers outstanding features and options that enhance the speed and accuracy of detection.

Image Performance: Superb Resolution and Clarity

The advanced imaging capability of the PX 10.10-MV raises the standard for large X-ray screening systems and delivers an array of features that give operators the information they need to clear suspicious items.

- The system's architecture optimizes belt height with a vertical geometry primary view that maximizes imaging performance and minimizes manual handling issues.
- Optional horizontal secondary view module can be added to provide operators with a second perspective, meeting regulatory requirements in many regions and applications.
- Comes standard with L-3's latest high-current X-ray source that delivers the ultimate in penetration, image resolution and quality.
- Best Image First™ feature automatically selects and presents the optimal view, enhancing throughput by reducing repetitive image adjustments.
- L-3's TRI-MAT imaging allows operators to easily distinguish between organic and inorganic materials and objects having a similar appearance but different chemical composition.
- User-friendly image enhancement tools, including continuously adjustable contrast, sharpening and color overlay, make it easy to optimize images for maximum detection capability.

Configurable: Operational Flexibility

Featuring the industry's most modular and flexible architecture, the PX 10.10-MV easily adapts to diverse and demanding operational requirements and evolving security challenges.

- Flexible architecture allows the system to remain compliant with the latest regulatory requirements. It can easily be expanded from one to two views in the field.
- Bi-directional operation allows two-way screening for facilities requiring inspection of both incoming and outgoing commodities.
- Adjustable conveyor can be inclined from a height of approximately 612 mm (24 in) to approximately 480 mm (19 in) to optimize freight handling.
- Customizable, user-defined Image Archiving (IA) stores up to 20,000 images.
- Modular architecture allows the system to be wheeled through a standard doorway in smaller segments that can easily and quickly be reconnected.

Operator Interface: Intuitively Simple

L-3's patented operator interface provides a simple, intuitive and flexible way for users to control the system and make the most of imaging information.

- User-friendly interface combines 3-button conveyor control with a touch-sensitive pad that allows continuous heads-up operation using icons displayed on the viewing screen.
- Ergonomically engineered console minimizes operator fatigue and reduces the physical stress associated with prolonged screening.
- Threat Image Projection (TIP) option inserts fictitious threat images at periodic intervals and tracks operator responses, motivating operators to stay alert and allowing supervisors to assess the effectiveness of screening operations.
- EU-approved TIP image libraries.
- Multi-language support* presents user interface instructions and messages in the operator's native language

Networking: Tying It All Together

The fully networkable PX 10.10-MV streamlines decentralized and remote monitoring, reporting and system management to help keep operational costs in line. Supervisors with appropriate network privileges can access and control any scanner or workstation on the LAN to send and receive bag images, TIP images, configuration settings, operator reports, diagnostics and operational metrics. This network capability, common to all L-3 PX second generation systems, has been designed to exceed current and emerging network requirements.

L-3's patented operator interface (remote console option shown) combines 3-button conveyor control with a touch-sensitive pad that allows continuous heads-up operation using icons displayed on the viewing screen



Single-view System

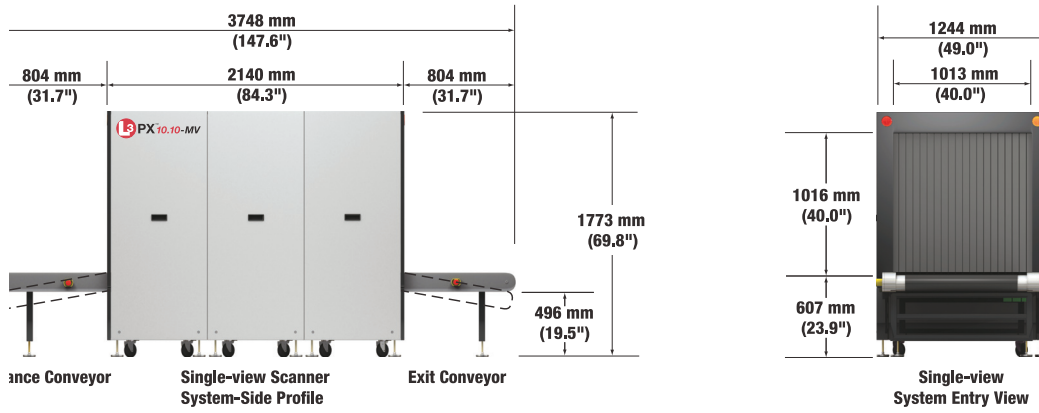

Dual-view System

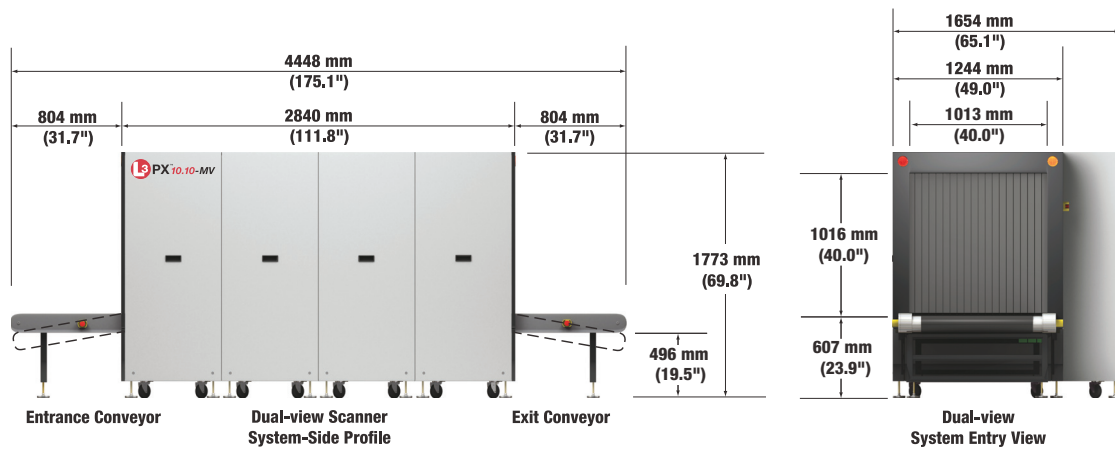

Features

Imaging Features

- 160 kVp high current X-ray source
- Continuously variable contrast adjustment
- Tri-material discrimination
- Transparent Color™
- Best Image First™
- Bi-directional scanning
- Organic/Inorganic stripping
- Metallic item removal
- Pseudo-color overlay
- True 32-bit color processing
- Edge enhancement
- Zoom 2X-16X or continuous zoom to 64X
- Reverse video
- Threat alert
- Customizable density and size alert
- High/low penetration mode

Standard Features

- Uninterruptible power supply (UPS) and input line filter
- Adjustable conveyor from 612 mm (24 in) can be inclined to optimize freight handling
- 22 in high-resolution LCD
- Patented heads-up operator display interface with touch pad control
- Configurable operator interface
- Operator Assist® (OA)
- Image Archiving (IA)
- Network ready
- Multi-language support*

Optional Features

- Various size LCD monitors
- Operator-proximity sensor footmat
- Threat Image Projection (TIP)
- EU-approved TIP libraries
- External UPS
- Color printer
- Remote operator interface (5 m, 30 m, and 100 m)
- Network supervisor
- Network TIP server
- Increased conveyor capacity (300 kg)

SPECIFICATIONS:

GENERAL

Dimensions

Single-view:	3748 mm (147.6") L x 1244 mm (49") W x 1773 mm (69.8") H
Dual-view:	4448 mm (175.1") L x 1654 mm (65.1") W x 1773 mm (69.8") H

Tunnel Opening: 1013 mm (40") W x 1016 mm (40") H

Conveyor Height: 607 mm (23.9") – can be inclined to 496 mm (19.5") if required

Power Requirements: 1Ø 100-240 VAC ±10% 50/60 Hz ±1%
1.5 KVA max

Conveyor Speed: 230 mm per second (9.05" per second)

Conveyor Capacity: 200 kg (440 lb)
Option: 300 kg (660 lb)

Weight

Single-view:	approx 1321 kg (2914 lbs)
Dual-view:	approx 1700 kg (3740 lbs)

Modular Construction: each module is built with a steel frame and panels on casters. Individual modules can pass through a standard doorway.

X-RAY

Source: 160 kV high current

Duty Cycle: 100%

Cooling: Sealed oil bath

Beam Orientation

Single-view:	Vertically upward
Dual-view:	Vertically upward and horizontal

X-ray Sensor(s): 1664 photodiodes per view in L-shaped folded array configuration

IMAGING AND PERFORMANCE**

Resolution: 38 AWG standard, 40 typical

Penetration: 40 mm of steel standard, 42 mm typical

Display Monitor: 22" high-resolution LCD

ENVIRONMENTAL

Operating Temperature: 0°C to 40°C (32°F to 104°F)

Storage Temperature: -20°C to 50°C (-4°F to 122°F)

Humidity: 95% non-condensing

Airborne Noise Level: <70dB (A)

RADIATION SAFETY

All L-3 Communications Security & Detection Systems' X-ray systems are certified to be in full compliance with all radiation safety requirements and external emissions limits as specified in the United States Code of Federal Regulations, Title 21, Section 1020.40 (21CFR1020.40) that apply to our products. Typical leakage radiation is less than 0.1 mR/hr compared to maximum of 0.5 mR/hr permitted by the Federal Standard.

OPERATIONAL STANDARDS

Complies with the U.S. Code of Federal Regulations:

FAA 14 CFR 108.17 Use of X-ray Systems

FAA 14 CFR 108.20 Use of Explosive Detection Systems

FAA 14 CFR 129.26 Use of X-ray System

CDRH 21 CFR 1020.40 Cabinet X-ray Systems

NRTL certified to ANSI/UL 61010-1, CAN/CSA 22.2 No. 61010-1 and CE compliant.

Complies with CDRH (FDA) requirements, including all labeling requirements.

FCC Class A Compliant

Film Safety

Ten passes of ISO 1600/33DIN high-speed photographic film.

DESIGN POLICY

L-3 Communications Security & Detection Systems reserves the right to change specifications in the course of continuous improvement. Specifications are provided for reference only and actual equipment may differ slightly from the description given. Typical dimensions are within ± 5% of nominal values.



Security & Detection Systems

Website: www.L-3com.com/sds
Email: inforequest.sds@L-3com.com

USA: Tel: +1 781 939 3800, Toll Free: 1 800 776 3031

United Kingdom: Tel: +44 (0) 1344 477900

Asia: Tel: +86 10 5976 1616

Australia: Tel: +61 3 8645 4500

Middle East: Tel: +971 4 609 1906

L-3 has made all reasonable efforts to ensure that the information in this document is accurate and complete, and disclaims any and all warranties for such accuracy and completeness, and is proprietary. This brochure consists of L-3 Communications Corporation general capabilities information that does not contain controlled technical data as defined within the Export Administration Regulations (EAR) Part 734.7-11.

© 2013 All rights reserved. L-3 Communications, Security and Detection Systems, Inc.

PX1010MV_PB_11DEC13

* Currently available in English, Russian and Chinese

** With L-3 standard test piece